

OWNER'S MANUAL

 **Polaris Watermatic**

---

C600 ORP/pH Controller

 **Polaris**



# Table of Contents

Introduction	2
Specifications	3
Components	4
Pre-installation	4
Dip Switch Settings	4
Acid/Base Feed	5
Optional Switch Settings	5
Installation	8
Feeding Systems	10
Site Assessment and Controller Installation	10
Flow Cell Assembly Installation	10
Flow Cell Switch Installation	14
Sensor Installation	15
Start-up Operation	15
pH Level Settings	16
Sanitizer Settings	17
Panel Features	19
Operation	20
Starting the Controller	20
Automatic Presets	20
Feed Light Activation	20
Out-of-range Alert	21
Manual Feed	21
Winterizing	21
Maintenance	22
Cleaning the Sensor Tips	22
Checking the ORP Sensor	22
Checking the pH Sensor	23
Troubleshooting	24
Guidelines for Using ORP for Water Maintenance	25
Warranty	27
Appendix	29



# Introduction

**For your protection, read all instructions carefully before installing or operating this automatic controller.**

The Polaris Watermatic® C600 ORP/pH Controller is designed to automatically monitor and maintain both the sanitizer level and the pH balance in swimming pools, spas, or any circulating water system that requires water chemistry management. The C600 Controller is designed for easy installation and simple operation. It may be used with liquid feed pumps, granular feeders, tablet erosion feeders, and ozone generators. It is not warranted or recommended for use with chlorine gas systems.

During the filtration cycle of the pool or spa, the sanitizer level and pH balance are maintained by a constant measurement of the ORP (Oxidation-Reduction-Potential) and pH balance of the water. Measurements are displayed on the controller's ORP and pH digital readouts (see drawing below). If the sanitizer level (ORP) falls below a predetermined set point, the controller will activate the chemical feeder until the preset point is reached. The pH is maintained in a similar manner. The C600 has two standard power receptacles for the ORP and pH outputs.

Various safety features prevent the feeder from activating if the sanitizer or pH balance are outside of the controller's range. These and additional features and options are described in detail in the Pre-installation section of this manual.

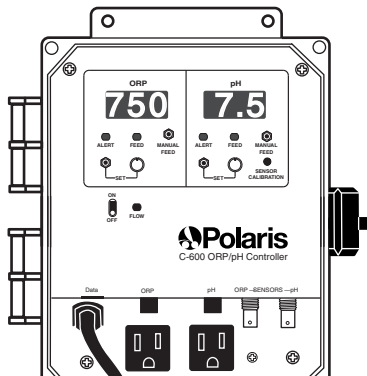

# Specifications

<b>pH Control Range:</b>	7.0 to 8.2
<b>ORP Range:</b>	100 mV to 900 mV
<b>Input Power:</b>	115 VAC 60 Hz, 3-wire grounded power cord. GFCI source required
<b>Controller Power:</b>	Less than .5 amp internally fused
<b>Output Power:</b>	115 VAC 60 Hz, 5 amp fused, two 3-wire grounded power receptacles
<b>Display:</b>	Digital readouts
<b>Operating Temperature:</b>	40 - 120° F
<b>Sensors:</b>	pH: glass combination with 10' cable ORP: platinum combination with 10' cable

## Selectable features:

- Desired ORP/pH settings
- pH calibration
- ORP and pH timed or continuous feed
- Safety interlock between pH and ORP
- Safety lockouts for low or high (out-of-range) pH or ORP levels
- Visual alert and optional audible alert for self-correcting and non-correcting conditions

**Note: When automating a body of water, size feeders so desired levels can be attained in short operating cycles. If feeders are unable to keep up with demand within a short time frame, automation becomes ineffective.**

# Components

The C600 ORP/pH Controller box contains:

- ORP/pH Controller
- Flow Cell Assembly (part# 9-700)
- ORP Sensor (part# 3-270)
- pH Sensor (part# 3-280)

# Pre-installation

## Dip Switch Settings

The controller is factory set to provide **continuous feed** of both ORP and pH. Before installing the controller, make sure that the dip switch settings are consistent with the settings shown below. To view or adjust the dip switch settings, unplug the controller from the power source, remove the face plate screws and expose the dip switches which are located on the back of the module (see the drawing below).

<b>pH Switches</b> (located behind the pH display)	<b>ORP Switches</b> (located behind the ORP display)
1. OFF	ON
2. OFF	ON
3. ON	OFF
4. OFF	ON
5. ON	ON
6. OFF	OFF
7. OFF	OFF
8. OFF	ON
9. ON	ON
10. OFF	OFF

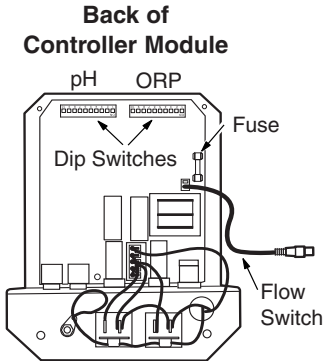

**Note:** For most controller applications, the continuous feed mode is appropriate. However, if using the controller in one of the following situations, the feed setting will need to be adjusted to allow for a timed-feed cycle followed by a delay cycle. Please refer to the Appendix for information on feed and delay settings if your application uses:

- a peristaltic pump to feed the sanitizer or pH and you are experiencing overfeeding.

- an erosion feeder with a spa or small body of water and you are experiencing spiking.
- the ORP sensor located downstream from the introduction of the sanitizer (the pH sensor should always be located upstream from the introduction of the pH balance).
- a Watermatic G1000 or G7500 feeder.

## Acid/Base Feed

The controller is preset at the factory to feed acid. If you are going to feed base, turn off pH switch #8.

### pH Dip Switch #8

ON = Acid Feed

OFF = Base Feed

## Optional Switch Settings

### 1. Sanitizer Feed Dependent on pH Being Within Range — pH Switch #1

The controller is preset at the factory to allow the ORP to feed regardless of the pH level.

Activating this switch will override this feature and allow the feeding of the sanitizer only if the pH reading is within the controller range (above 7.0 or below 8.2). Since the ORP reading is dependent on the pH (i.e. as the pH rises, the ORP lowers), this setting avoids oversanitizing as a result of an out-of-range pH level. If the pH is out of range, the sanitizer will not feed but the pH alert light will illuminate.

### 2. ORP and pH Simultaneous Feeding—pH Switch #2

The Controller is preset at the factory to allow simultaneous feeding of pH and ORP.

When turned on, this switch will not allow ORP and pH to feed at the same time. In some installations, the sanitizer and the pH are introduced into the filtration system in close proximity to each other. Simultaneous feeding of acid for pH control and liquid chlorine to sanitize can cause chlorine gas bubbles in the return lines. This option prevents the sanitizer from feeding until the pH feed cycle is complete.

**Note:** If the system runs out of acid to feed, the pH feeder will continue to run and the sanitizer feeder will not be activated.

**3. High pH Alert for Acid Mode and Low pH Alert for Base Mode—pH Switch #9**

The controller has a pH operating range of 7.0 to 8.2. If the pH reading falls outside of this range for more than 10 minutes, the pH alert light comes on and the unit will not feed.

If feeding acid in a system where the pH frequently jumps above 8.2, cancel the high pH alert by moving the pH switch #9 to the OFF position. The alert light will not come on and the unit will continue to feed.

If the sensor fails, the pH could continue to feed, adding an excessive amount of acid to the pool. For this reason, **we strongly recommend leaving the pH switch #9 in the ON position and instead using the maximum feed time feature.**

If feeding base, cancel the low pH alert by moving the pH switch #9 to the OFF position.

**4. Low ORP Shutoff—ORP Switch #9**

The controller is programmed to shut down when the ORP level drops below 100 mV for more than 10 minutes. This prevents overfeeding if there is an ORP sensor failure. To cancel this feature, move the ORP switch #9 to the OFF position.

This change might be required for spas or extremely small bodies of water where sudden organic loads dissipate the sanitizer in a very short time.

**5. Setting a Maximum Feed Time**

As an added safety feature, some operators set maximum allowable feed times for their sanitizer and pH. These times represent the maximum time either system would run under normal operation. If the feed times reach the predetermined maximum time limits (due to some malfunction), the system shuts down and the controller goes into the service mode (the entire display flashes). To reset, remedy the malfunction and turn the controller off and then on.

To set a maximum feed time, set the dip switches as shown below.

<b>Maximum* Feed Time</b>	<b>pH Switches</b>		<b>ORP Switches</b>	
	<b>#3</b>	<b>#4</b>	<b>#3</b>	<b>#4</b>
60 Minutes	ON	ON	ON	ON
120 Minutes	OFF	ON	OFF	ON
240 Minutes	ON	OFF	ON	OFF
NO LIMIT	OFF	OFF	OFF	OFF

\*This maximum feed time option is only available when in the continuous feed mode. It is unlikely that feed times will exceed one hour with properly sized feeders.

# Installation

## Liquid Feeder

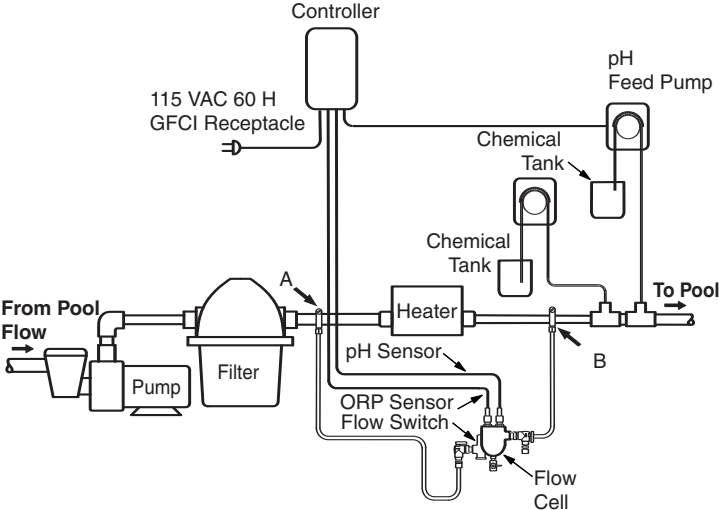

## Erosion Feeder

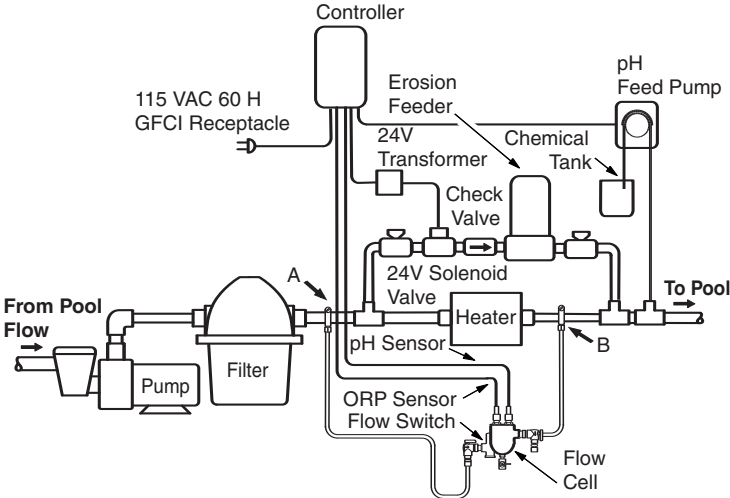

**NOT RECOMMENDED FOR BELOW WATER LEVEL APPLICATIONS.**

**Typical Installation**

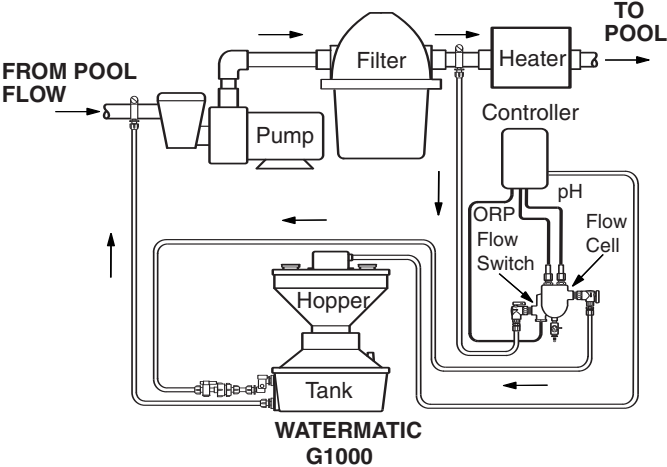

## Feeding Systems

Install the chemical pump and erosion feed systems as shown in one of the figures on the previous pages. If your model differs from these systems, see the installation manual that was provided with it for the appropriate installation method. The controller may have to be set for the particular feeder system used. See the **Appendix** for instructions.

## Site Assessment and Controller Installation

Before installing the controller, it is important to do a site assessment and consider where and how you will mount the controller. The controller should be mounted on a wall or other surface within eight feet of the feeder, at least ten feet away from the edge of the water, in close proximity to the time clock and within six feet of the GFCI power source.

Once the best site is determined, obtain all necessary mounting screws or anchors (no mounting screws are provided with the controller). Securely mount the controller on a wall or panel.

## Flow Cell Assembly Installation

Locate the flow cell within eight feet of the controller, mounted as shown. The flow cell must be plumbed so the pressure difference between the inlet (flow switch side) and the outlet is sufficient to ensure flow through the flow cell. If the 3/8" tubing provided is being used, a minimum pressure differential of 3 PSI and 0.3 GPM is required to activate the flow switch. It is also desirable to have filtered water pass over the sensors to minimize cleaning.

### Flow Cell Assembly

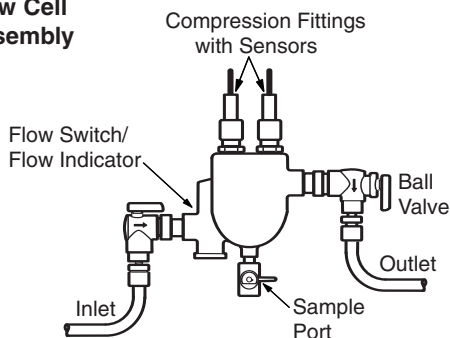

There are three suggested methods to install the flow cell.

1. Plumb the inlet to the flow cell after the filter and plumb the outlet of the flow cell after the heater using the saddle clamps provided. See the Pressure Differential Installation diagram. Fittings for 1/4" NPT taps are included.

**Pressure Differential Installation**

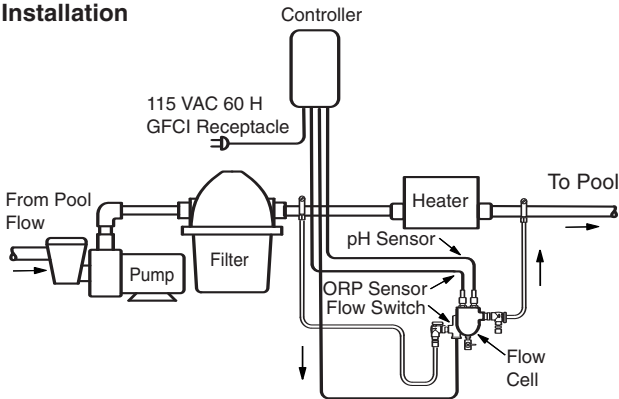

2. Plumb from after the filter to before the pump. This ensures excellent flow but the flow will need to be adjusted so the sensors are not subjected to a suction environment. See the Pressure Suction Installation diagram. Open the sample port (see Flow Cell Assembly drawing) to verify the water is flowing freely from it.

**Pressure/Suction Method**

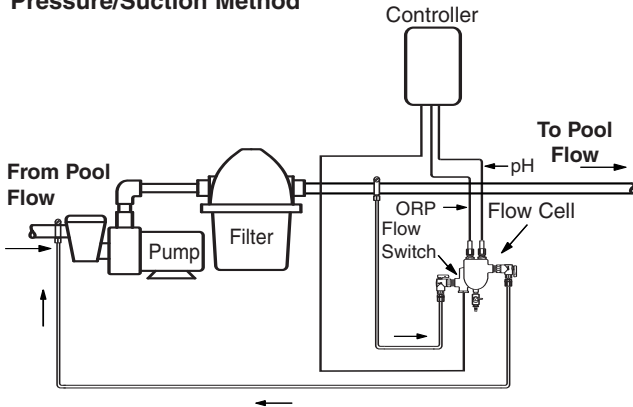

- Plumb from before the filter to after the heater, using an inline filter to minimize debris coming into contact with the sensors. See the Pressure Differential Alternative Installation diagram.

### Pressure Differential Alternative Installation

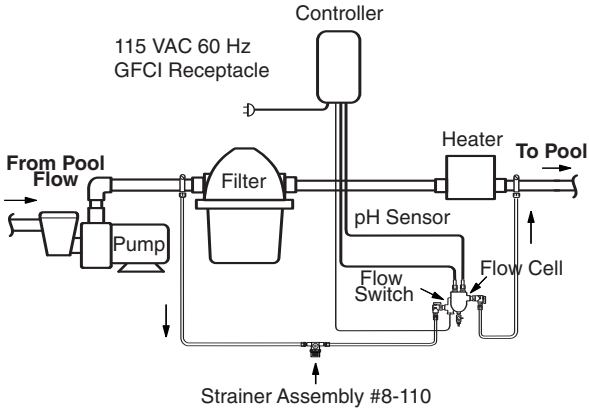

### G7500 Granular Feeder Installation

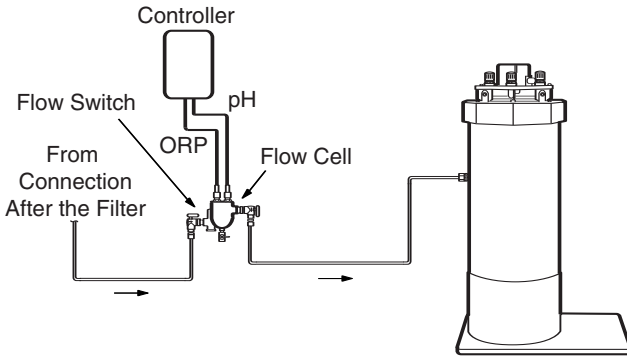

**Note:** Solar systems and other factors can alter pressure differentials in a system, adversely impacting flow through the flow cell.

The flow cell comes fully assembled in the box. It is setup to use with the 3/8" tubing provided; however, other sized tubing or 1/2" hard plumbing can be used. To use an alternative tubing, remove the 90° on/off valves and plumb according to the application.

1. **If using a saddle clamp**, drill a 7/16" hole in the pipe on the pressure side of the pump. Thread the 1/8" Jaco fitting (#2 in diagram below) through the clamp (#3) and place the nylon jam nut (#4) onto the Jaco fitting. Slide the pipe seal washer (#5) onto the end of the Jaco fitting. Insert the completed assembly into the hole in the pipe and tighten the clamp. Test for leaks.

If the pipe is larger than 2" in diameter, two clamps joined together will be required per each hole.

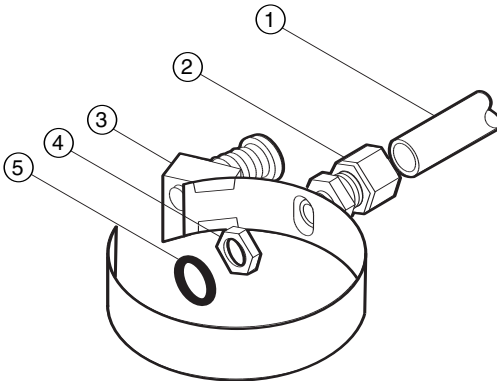

**If using a pipe tap**, drill a 7/16" hole and tap a 1/4" NPT hole. Apply RTV silicone, teflon stick or teflon paste to the threads on the Jaco fitting and screw securely into the pipe. Test for leaks.

- 2.. Cut the tubing (#1) to the appropriate length. Slightly loosen the Jaco fitting in the pipe and insert the tubing into it. Take the free end of the tubing and insert it into the Jaco fitting on the flow switch side of the flow cell.
3. Complete these steps for the return side of the flow cell. Use the appropriate remaining parts to complete this task. Take the free end of the tubing and insert it into the Jaco fitting on the outlet side of the flow cell.

## Operating Tips:

It is imperative that the system has proper flow past the sensors when the pool filtration system is running. **A flow cell must be used with any system using peristaltic pumps.**

Installation after the pool filter, which passes filtered water over the sensors, will extend the time between sensor cleanings.

## Flow Switch Installation

It is recommended that the controller be used with a flow switch to ensure that feeding does not occur when the main filter/circulation pump is not running. To install:

1. Remove the four screws securing the control module and detach it from the box.
2. Locate the flow jumper cable.
3. Remove the black jumper from the back of the control module and plug in the flow jumper cable. Save the black jumper for possible future use.

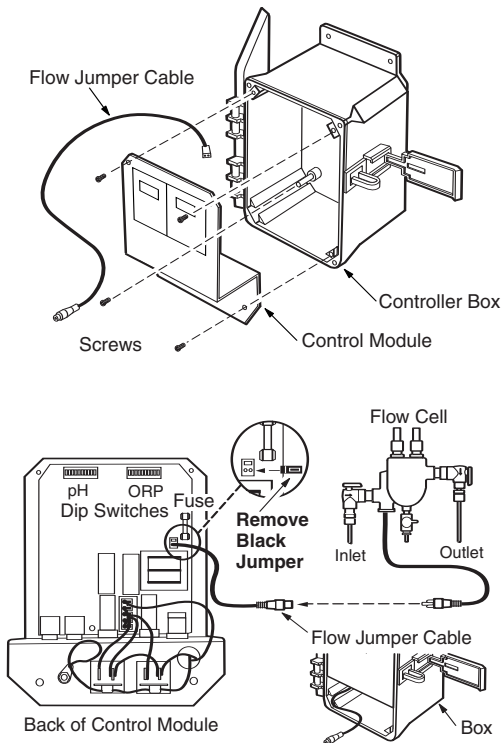

4. Feed the flow jumper cable out of the lower opening on the front of the box as shown.
5. Re-install the control module with screws.

## Sensor Installation

Carefully unpack the ORP and pH sensors, and the o-rings included in the bottles. Remove the protective caps from the sensor tips. Store the protective caps inside the controller enclosure for future use when winterizing or reshipping.

Attach the pH and ORP sensor BNC connectors to the controller (see Panel Features diagram).

Remove the compression fitting nuts from the flow cell assembly and slide them onto the sensors. Insert the sensors through the o-rings and into the compression fittings on the flow cell until the sensor tips are below the water line in the pipe. Hand tighten the nuts of the fittings. **DO NOT USE A WRENCH.**

Make sure the controller power switch is OFF. Plug the power cords from the pH and ORP feeder into the controller. Plug the power cord from the controller into the GFCI receptacle.

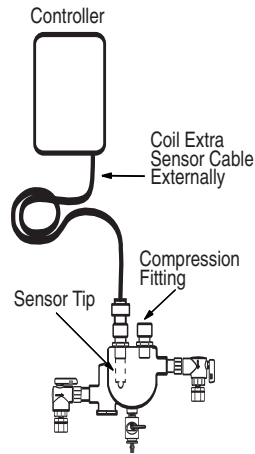

## Start-up Operation

Do not add chemicals to the feeders until all of the following start-up operations have been completed.

1. Turn the filter pump on and check for water flow through the flow cell assembly. Water should pass over the ORP and pH sensors for at least five minutes to allow for accurate ORP and pH readings from the pool or spa.
2. Check for leaks and correct as necessary.
3. Turn the ORP set knob (#5 on Panel Features diagram) to counterclockwise to minimum.

4. Hold in the pH set button (#4) and adjust the pH set knob (#15) to maximum (clockwise) if in the base feed mode or minimum (counterclockwise) if in the acid feed mode.
5. Turn on the power switch. The red power indicator light and the digital display will activate.

If the ORP and pH lights are illuminated but the power light is not, there is no flow or pressure and the feed cycles are inactive. If the flow switch is not being used and the power light is off, the flow jumper on the back of controller module is not in place.

6. Using a DPD test kit, manually adjust the pool water to the desired sanitizer and pH levels.

## **pH Level Setting**

1. Prior to setting the desired pH level, the pH sensor must be calibrated. To do this, the pH sensor must be placed in a known pH solution that is near 7.5. If the pH sensor is installed in a flow cell with a sample port, test the water from the sample port. If it is installed in a position where the direct water that the sensor is sitting in cannot be tested, place the sensor in a glass of pool water.

Calibrate the sensor to the reading by adjusting the calibration set knob (see Panel Features diagram). The pH sensor should be calibrated every 4 to 8 weeks.

2. Turn the pH set knob until the desired pH level appears in the display. Acceptable levels are 7.2 to 7.8.
3. Allow the system to operate for 24 hours. With the filtration system running, retest the pool water pH using a test kit and adjust the pH set knob if necessary.
4. Adjust the pH feed system for a feed rate that is not too low or too high. Be aware of the lag time between the beginning of the chemical feed cycle and the sensor detection of the chemical levels after recirculation through the pool or spa. A low feed rate can either cause the feeder to lag or the feeding to be extended, and a high feed rate can result in too much pH being added.

To check the feed rate, use a test kit to test the pH balance of the water immediately after a pH feed cycle ends. If the pH is high (above the preset point of the pH set point), the feed rate is too high. If overfeeding persists, timed feed may be required. (see the Appendix).

**Note:** When feeding liquid (muriatic) acid, it is generally advisable to dilute the acid (in the water) to avoid overshooting the set point. The smaller the body of water, the greater the need to dilute the acid.

5. The green pH feed light will activate only when the controller is operating the pH feeding system.

To verify the acid/base feed mode, set the desired pH above the pH indicated on the digital display. The feed light should come on if the controller is set for acid feed. If the controller is set for base feed, the feed light will come on when the desired pH is set below the pH indicated on the digital display. The unit is normally set for the acid feed mode unless specified for base feed.

## Sanitizer Settings

This controller displays direct ORP readings and bases the control on this reading, not a parts per million (ppm) reading. The ppm is a calculated number that must be calibrated and should be used accordingly. While ORP indicates the effectiveness of the sanitizer, it does not directly correlate to a ppm reading. If you desire ppm, use the ORP reading as a relative indication of the sanitizer level. Use a DPD test kit to measure the free chlorine. If you need more sanitizer than that indicated by the ORP display, set the desired level above that point. If you require less sanitizer, set the desired level below that point.

**Note:** The ORP set knob (see Panel Features diagram) is very sensitive; an adjustment from 700 to 750 mV could increase the sanitizer level by several parts per million.

1. Hold in the ORP set button, then turn the ORP set knob until the desired ORP level appears in the ORP display. Release the button. After six seconds, the digital display reverts back to the pool reading. The World Health Organization suggests maintaining an ORP at or above 650 mV. This is a good starting point.

2. Allow the system to operate for 24 hours. With the filtration system running, retest the sanitizer level and adjust the ORP set knob if necessary.
3. The feed rate of the sanitizer feeder should be adjusted in the same manner as the pH feeder.
4. The yellow ORP feed light will activate only when the controller is operating the ORP feed system.

**Note:** In continuous feed, the feed light will flash while feeding. If using timed feed/delay (see the Appendix), the feed light will flash during the feed cycle and remain on constantly during the delay cycle.

# Panel Features

#	DESCRIPTION	FUNCTION
1.	ORP Digital Display	Indicates sanitizer level
2.	ORP Manual Feed Button	Instantly feeds sanitizer (if feed light is off)
3.	ORP Alert Light	Indicates the ORP level is out of range
4.	ORP Feed Light	ORP sanitizer feeder is activated (or in delay)
5.	ORP Set Button	Holding in allows sanitizer level to be changed
6.	ORP Set Knob	Sets the desired sanitizer level of the water
7.	Power On/Off Switch	Turns power on and off
8.	ORP Flow Light	Indicates there is sufficient flow/pressure to operate
9.	Data Port	Optional accessories connection
10.	Power Cord	3-wire grounded power cord with plug
11.	pH Digital Display	Indicates pH level
12.	pH Alert Light	Indicates that pH is out of range
13.	pH Manual Feed Button	Instantly feeds pH (if feed light is off)
14.	pH Feed Light	Indicates the pH feeder is activated (or in delay)
15.	Calibration Set Knob	Calibrates the pH sensor
16.	pH Set Knob	Sets the desired pH level of the water
17.	pH Set Button	Holding in allows desired pH level to be changed
18.	Fuses	Continuous feed = 5 amp, timed feed = 1.6 slo-blo
19.	ORP and pH Sensor Connectors	BNC jacks
20.	5 amp ORP/pH Outlets	3-wire grounded power receptacles

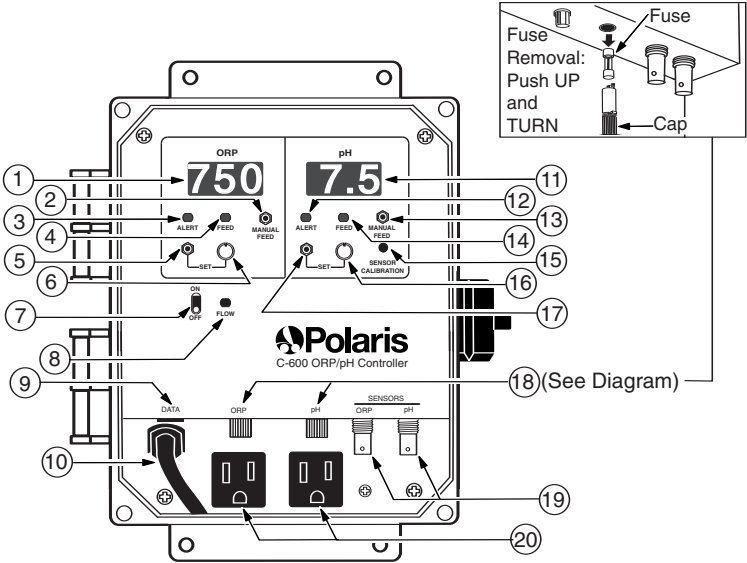

# Operation

## Starting the Controller

Prior to starting the system, balance the body of water to approximate the desired levels. The controller should be used to maintain the body of water and not to balance it.

When the controller power switch is ON, the red flow light and the ORP and pH digital display will come on. Once initiated, the controller has a one minute delay to avoid unnecessary feeding.

**If a flow switch is being used and the system does not have sufficient flow or pressure, the array lights will be on but the power light will be off. In this condition, the controller will not feed.**

## Automatic Presets

When the controller is initially powered up, the ORP setting will be 650 mV and the pH setting will be 7.4. If the controller loses power or the power is turned off, the settings will revert back to the 650 mV and 7.4 pH. If the controller is turned off by the Watermatic pressure or flow switch, the settings will remain at the dose set by the operator.

## Feed Light Activation

1. The ORP feed light (#4 on Panel Features) will flash to indicate that sanitizer is being dispensed. The pH feed light (#14) will flash to indicate that pH is being dispensed.
2. Do not adjust the set knobs when the sanitizer/pH are feeding (feed light is flashing). When the system is feeding, the digital display may register an inaccurate sanitizer/pH level because the system is still circulating the sanitizer/pH.
3. The system can be set for timed feed and delay cycles. (see Appendix). This method is used to prevent too much sanitizer or pH from being dispensed into a small pool or spa. Once the feeder has dispensed a dose of sanitizer or pH, the feeder will not dispense again for a set period of time. This delay allows the sanitizer/pH to be circulated through the pool or spa and returned through the filtration system where the sensors test the sanitizer/pH level. After the delay period, another dose of sanitizer/pH will be dispensed if needed.

## Out-of-range Alert

1. Unless the ORP dip switch #9 has been turned off (see Optional Switch Settings), the ORP alert light will flash when the ORP has been out-of-range (less than 100 mV or more than 900 mV) for ten consecutive minutes. Once the alert light comes on, the controller will stop activating the feeder.
2. Unless the pH switch #9 has been turned off (see Optional Switch Settings), the pH alert light will flash when the pH has been out-of-range (less than 7.0 or more than 8.2) for ten consecutive minutes. Once the alert light comes on, the controller will stop activating the feeder.
3. Once the out-of-range condition has been corrected, the controller will reactivate automatically. After a one-minute delay, it will activate the feeders, if necessary.

## Manual Feed

1. The Manual Feed setting can be used to manually dispense sanitizer/pH. To signify that the controller is feeding chemical, the alert light will come on when the manual feed button is pushed.
2. The Manual Feed setting cannot be used while the feed light is on, i.e. feeder is activated or in delay.

## Winterizing

If the system is subject to extended shutdowns or is located in colder climates, it is important to winterize the system.

1. Turn off the main power to the controller.
2. Loosen the compression fitting nuts and gently remove the sensors from the flow cell assembly. **The sensor tips must be stored in a protective cap or bottle filled with a liquid solution of one teaspoon salt and three teaspoons water.** Mix the solution thoroughly and make sure the tips of the sensors are completely covered. **STORE THE SENSORS IN A WARM PLACE – THEY SHOULD NOT BE EXPOSED TO FREEZING TEMPERATURES.**
3. Drain the water from the flow cell/flow switch assembly.

# Maintenance

## Cleaning the Sensor Tips

1. It is important to keep the sensor tips clean to ensure accurate readings. When the sensor tips become dirty, they can read a lower than actual sanitizer/pH level which can cause incorrect disbursements.

**Note:** A sensor tip coated with calcium scale will not look visibly dirty.

2. As a general rule, the sensor tips should be cleaned every two to four weeks for commercial pools and spas, and once each month for residential pools and spas. However, cleaning frequency can vary from one body of water to another.

To determine the appropriate frequency for your pool or spa, note reading prior to cleaning. After cleaning the sensor, allow a stabilizing period of approximately ten minutes. If the reading is identical to the reading prior to cleaning, the sensor was not dirty and the time between sensor cleanings can be increased.

3. To clean the sensor tip, turn off the controller, loosen the compression fitting nut and gently remove the sensor from the flow cell. Swirl the tip for five seconds in muriatic acid (diluted 5 to 1) or white vinegar and rinse it in water. **Do not touch, wipe or brush the end of the sensor.** For commercial pools and spas, on every third cleaning, swirl the sensor tip in a solution of liquid soap and water. Rinse with water.
4. Gently place the sensor back into the flow cell assembly and turn on the controller.
5. Allow the controller to operate for a few minutes to get an accurate reading. Adjust the set knob if necessary.

## Checking the ORP Sensor

1. The ORP sensor should be checked every six months or anytime the feeder oversanitizes the water.
2. Clean the sensor tip as noted above.

3. Place the sensor in a clean glass of tap water. This should give a reading of between 200 and 400 mV. Adding a pinch of Dichlor or Trichlor should cause the ORP level to jump to between 750 and 800 mV. If a sanitizer with a high pH such as calcium hypochlorite or liquid chlorine (sodium hypochlorite) is used, the ORP level may only rise to between 650 and 750 mV.
4. If the sensor does not respond as indicated, the sensor should be replaced.

### **Checking the pH Sensor**

1. The pH sensor should be checked every six months or anytime the pH goes out of range.
2. Place the sensor in a clean glass of tap water. Add a small amount of acid to the glass. The pH reading should drop to the lowest red light. Then place the sensor in a solution with a pH above 7.5. The pH reading should move up.
3. If the sensor does not respond as indicated, the sensor should be replaced.

# Troubleshooting

PROBLEM	POSSIBLE CAUSE	SOLUTION
SANITIZER LEVEL TOO LOW	Set knob set too low	Adjust knob clockwise until the proper sanitizer level is reached and stabilized
	pH level too low (less than 7.2)	Check pH level with a test kit and adjust as required
	Chemical feeder empty	Refill chemical feeder
	Controller malfunction	Replace controller module
	Sensor failure	Replace sensor
SANITIZER LEVEL TOO HIGH	Sensor dirty	Clean according to the maintenance instructions
	Set knob set too high	Test the sanitizer with a test kit and adjust the ORP knob counterclockwise until the proper sanitizer level is reached
	pH too high (above 7.8)	Check pH level with a test kit and adjust as necessary
pH LEVEL TOO LOW	Set knob set too low	Adjust pH set knob
	pH calibrate knob improperly adjusted	Adjust pH calibrate knob
	Chemical feed rate too high	Lower feed rate
	Chemical feeder empty (if using base)	Refill chemical feeder
	Controller malfunction	Replace controller module
	Sensor failure	Replace sensor
pH LEVEL TOO HIGH	Sensor dirty	Clean according to the maintenance instructions
	pH sensor calibration improperly adjusted	Adjust pH sensor calibration
	pH set knob set too high	Adjust knob counterclockwise
	Chemical feeder empty (if using acid)	Refill chemical feeder
	Feed pump malfunction	Repair feeder pump
	Chemical feed rate too low	Increase feed rate
RED pH ALERT LIGHT ON	pH level is below 7.0 or above 8.2	Manually adjust pH in the pool
DISPLAY LIGHTS OFF	No power supply	Check circuit breaker
FEEDER DOES NOT OPERATE	Bad fuse	Replace fuse

# Guidelines for Using ORP for Water Maintenance

- Q. Why should I maintain a pH level between 7.2 and 7.8?
- A. pH levels below 7.0 can cause eye irritation, metal corrosion, etching of plaster, stains, damage to vinyl liners, and loss of sanitizer. In addition to eye irritation, pH levels above 8.0 can cause cloudy water, scale formation and loss of sanitizer efficiency (low ORP).
- Q. How do I increase the pH level?
- A. Small amounts of basic (alkaline) chemicals such as pH Plus or pH Up can be added.
- Q. How do I lower the pH level?
- A. Small amounts of liquid (muriatic) acid or dry acid (sodium bisulfate) such as pH Minus or pH Down can be added.
- Q. How does 650 mV relate to the ppm of chlorine?
- A. Pure water, without conditioner, at a pH level of 7.5 corresponds to approximately 1.5 ppm of chlorine. Actual pool or spa water usually takes at least 1-2 ppm of chlorine to generate 650 mV ORP (although the Total Dissolved Solids and pH can affect the activity of the chlorine and thus change the level of ORP).
- Q. Does an ORP of 650 mV stop algae?
- A. No. Because algae is a living organism that adapts genetically to a constant level of sanitizer, the periodic addition of an algicide or shocking may be necessary. Please note that the addition of some chemicals can change the ORP readings for up to several days.
- Q. What causes a low ORP?
- A. A low sanitizer level, a pH level above 8.0, a conditioner level above 200 ppm or a TDS (Total Dissolved Solids) above 3,000 ppm can all cause a low ORP.

Q. How do I make sure the ORP sensor is working properly?

A. Watch the sensor reading when adding sanitizer. If it does not respond properly, follow the recommended sensor tip cleaning procedures outlined in the Maintenance section. If cleaning does not solve the problem, check the sensor as directed in the Maintenance section.

Q. How should the ORP sensor respond to adding acid?

A. Adding acid decreases the pH level thus increasing the ORP.

Q. How should the ORP sensor respond to adding base?

A. Adding base increases the pH level thus decreasing the ORP.

Q. How should the ORP sensor respond to adding sanitizer?

A. Depending on the type of sanitizer used, the ORP should increase. A sanitizer high in base, such as liquid chlorine (sodium hypochlorite) or a dry chlorine powder (calcium hypochlorite); however, can cause the pH level to rise and the ORP to decrease. The pH level must be in the ideal range to maintain the proper ORP level.

Q. Can ORP be used with ozone?

A. Even though ozone is an excellent oxidizer, it has a very short lifetime. Therefore, a chlorine or bromine residual will still be needed in order to maintain the proper ORP level.

**When using ozone, the ozone must be introduced into the system downstream from the sensors.**

Q. Can ORP be used with UV or metal ions?

A. Only if the proper chlorine or bromine residual is maintained.

# WARRANTY

## **Polaris Watermatic C600 ORP/pH Controller**

This limited warranty is extended to the original consumer purchaser of this Polaris Watermatic C600 Controller manufactured by Polaris Pool Systems, Inc., 2620 Commerce Way, Vista, CA 92081-8438, USA.

Polaris Pool Systems warrants the Watermatic Controller it manufactures, including all parts and components thereof, to be free of defects in material and workmanship. For questions regarding your Polaris Watermatic Controller, please feel free to call or write us. Be sure to provide the serial number of your unit.

The warranty commences on the date of installation of the controller and shall remain in effect for a period of one (1) year, but in no event shall it be in effect for more than two (2) years from the date of manufacture of the controller as established by the serial number.

This limited warranty does not apply if the failure is caused or contributed by any of the following: improper handling, improper storage, abuse, unsuitable application of the unit, lack of reasonable and necessary maintenance, winter freezing or repairs made or attempted by other than Polaris Pool Systems or one of its authorized service centers. Polaris will repair or replace, at its option, a unit or part proved to be defective within the warranty period and under the conditions of the warranty.

Unless local repair is authorized, the consumer must deliver or ship the unit or the warranty parts, freight prepaid to the nearest Polaris Authorized Service Center or return it freight prepaid (after proper authorization) to the plant of manufacture. Authorization to return a unit to the plant of manufacture must be obtained from the Polaris Customer Service Department. For your convenience, please check with your dealer for the local procedure before exercising this warranty. If further directions or instructions should be required, contact the Customer Service Department at 1-800-VAC-SWEEP (USA and Canada only) or 760-599-9600. Be sure to insure your shipments against loss or damage during transit.

Polaris is not responsible for the cost of removal of the unit, damages due to removal, any other expenses incurred in

shipping the unit or parts to or from the factory or its authorized service centers, the installation of the repaired or replacement unit. The consumer must bear these expenses.

This warranty does not cover repair or replacement of a unit except at our factory or a Polaris Authorized Service Center.

THIS LIMITED WARRANTY IS IN LIEU OF ALL OTHER WARRANTIES, EXPRESS OR IMPLIED, INCLUDING THE IMPLIED WARRANTIES OF MERCHANTABILITY AND FITNESS FOR A PARTICULAR PURPOSE, AND ALL SUCH OTHER WARRANTIES ARE DISCLAIMED EXCEPT TO THE EXTENT ANY IMPLIED WARRANTY MAY BE IMPOSED BY STATE CONSUMER LAW. ANY SUCH IMPLIED WARRANTY IMPOSED BY STATE CONSUMER LAW IS LIMITED IN DURATION TO ONE (1) YEAR FROM DATE OF PURCHASE.

IN NO EVENT SHALL POLARIS POOL SYSTEMS BE LIABLE FOR INCIDENTAL OR CONSEQUENTIAL DAMAGES OF ANY NATURE OR KIND OR FOR DAMAGES TO PERSONS OR PROPERTY, INCLUDING ANY DAMAGE RESULTING FROM THE USE OF THE POLARIS WATERMATIC CONTROLLER.

Some states do not allow limitations on how long an implied warranty lasts, or the exclusion or limitation of incidental or consequential damages, so the above limitations may not apply to you.

This limited warranty is valid only in the United States of America and Canada, and it does not apply to Polaris Watermatic Controllers sold or installed in any other country.

# Appendix

For most controller applications, the continuous feed mode is appropriate. However, when using the controller in one of the following situations, the controller settings should be changed to allow for a timed-feed cycle followed by a delay cycle.

- Using a peristaltic pump to feed the sanitizer or pH and you are experiencing overfeeding
- Using an erosion feeder with a spa or small body of water and you are experiencing spiking
- The ORP sensor is located downstream from the introduction of the sanitizer (the pH sensor should always be located upstream from the introduction of the pH balance)
- With a Watermatic G1000 or G7500 feeder

Descriptions of the various feed settings are detailed on the following pages.

Once the appropriate feed and delay cycle times are chosen, allow the system to run for a few days. Then adjust the feed cycle longer if the water is undersanitized or shorter if the water is oversanitized. The delay cycle can also be shortened if the feeder cannot keep up with the demand.

The ORP and pH sides of the controller can be modified independently. For example, the pH side can be left in continuous mode while the ORP side is set for a timed feed, and vice versa. This versatility allows you to choose the optimal settings for your controller application.

## Summary of Dip Switch Settings

### ORP Switches

(located behind the ORP display)

	<u>Description</u>
1	Always on
2	Always on
3	Feed Cycle Setting
4	Feed Cycle Setting
5	Delay Cycle Setting
6	Delay Cycle Setting
7	OFF = Pool Mode (longer feed and delay cycles for a larger body of water) ON = Spa Mode (shorter feed and delay cycles for a smaller body of water)
8	OFF = Feed Cycle in Seconds ON = Feed Cycle in Minutes
9	ON = Alert for low ORP
10	OFF = Timed Feed ON = Continuous Feed

### pH Switches

(located behind the pH display)

	<u>Description</u>
1	ON = No ORP feed if the pH is out of range OFF = ORP feed regardless of the pH
2	ON = No ORP feed while the pH is feeding OFF = ORP and pH can feed simultaneously
3	Feed Cycle Setting
4	Feed Cycle Setting
5	Delay Cycle Setting
6	Delay Cycle Setting
7	OFF = Feed Cycle in Set ON = Feed cycle in Minutes
8	OFF = Base Feed ON = Acid Feed
9	ON = Alert for high and low pH
10	OFF = Timed Feed ON = Continuous Feed

## Peristaltic Pump is Overfeeding Sanitizer or pH

When using the controller with a peristaltic pump, which feeds slowly, it is better to have a very long feed cycle in order to provide adequate sanitizer or pH control.

1. Timed Feed Mode = ORP and pH Switch #10 are O
2. Feed Cycle in Minutes = ORP Switch #8 is ON  
pH Switch #7 is ON
3. Pool Mode = ORP Switch #7 is OFF  
Spa Mode = ORP Switch #7 is ON
4. Choose the desired feed and cycle delay times from the following options.

### Recommended Settings

#### ORP SWITCHES

Feed Cycle	Switch #3	Switch #4	Delay Cycle	Switch #5	Switch #6
12 Minutes	OFF	ON	5 Minutes	OFF	OFF

#### pH SWITCHES

Feed Cycle	Switch #3	Switch #4	Delay Cycle	Switch #5	Switch #6
8 Minutes	ON	ON	5 Minutes	OFF	OFF

### Optional Settings

#### ORP SWITCHES

##### Pool Mode (#7 OFF)

Feed Cycle	Switch #3	Switch #4
12 Minutes	OFF	ON
16 Minutes	OFF	OFF
24 Minutes	ON	ON
32 Minutes	ON	OFF

Delay Cycle	Switch #5	Switch #6
2 Minutes	OFF	ON
5 Minutes	OFF	OFF
10 Minutes	ON	OFF
20 Minutes	ON	ON

##### Spa Mode (#7 ON)

Feed Cycle	Switch #3	Switch #4
2 Minutes	OFF	ON
4 Minutes	OFF	OFF
6 Minutes	ON	ON
8 Minutes	ON	OFF

Delay Cycle	Switch #5	Switch #6
1 Minutes	ON	ON
2 Minutes	OFF	ON
5 Minutes	OFF	OFF
10 Minutes	ON	OFF

## pH SWITCHES

Feed Cycle	Switch #3	Switch #4	Delay Cycle	Switch #5	Switch #6
4 Minutes	OFF	ON	2 Minutes	OFF	ON
8 Minutes	ON	ON	5 Minutes	OFF	OFF
16 Minutes	OFF	OFF	10 Minutes	ON	OFF
32 Minutes	ON	OFF	20 Minutes	ON	ON

## Erosion Feeder on a Spa or Small Body of Water is Causing Spiking

When using the controller with an erosion feeder system, which continues to dissolve sanitizer while in the off mode, it is better to have a very short feed cycle followed by a delay that allows the sanitizer to circulate past the sensors. This is especially important in spas or small bodies of water.

1. Timed Feed Mode = ORP Switch #10 is OFF
2. Feed Cycle in Seconds = ORP Switch #8 is OFF
3. Spa Mode = ORP Switch #7 is ON
4. Choose the desired feed and delay cycle times from the following options.

### Recommended Settings

#### ORP SWITCHES ONLY

Feed Cycle	Switch #3	Switch #4	Delay Cycle	Switch #5	Switch #6
9.6 Seconds	ON	ON	5 Minutes	ON	ON

### Optional Settings

#### ORP SWITCHES ONLY

##### Pool Mode (#7 OFF)

Feed Cycle	Switch #3	Switch #4
4.8 Seconds	ON	OFF
7.2 Seconds	OFF	OFF
9.6 Seconds	ON	ON
14 Seconds	OFF	ON

##### Spa Mode (#7 ON)

Feed Cycle	Switch #3	Switch #4
6 Seconds	OFF	OFF
1.2 Seconds	ON	ON
2.4 Seconds	OFF	ON
3.6 Seconds	ON	ON

**ORP SWITCHES ONLY**

Delay Cycle	Switch #5	Switch #6	Delay Cycle	Switch #5	Switch #6
5 Minutes	ON	ON	2 Minutes	ON	OFF
10 Minutes	ON	OFF	5 Minutes	OFF	OFF
20 Minutes	OFF	OFF	10 Minutes	OFF	ON
30 Minutes	OFF	ON	15 Minutes	ON	ON

**Sensor Located After Sanitizer Introduction**

When using the controller in an installation where the sensor is located downstream of the introduction of the sanitizer, there is a potential for the sensor readings to be inaccurate. Since this installation is generally associated with sanitizer tablets, which dissolve slowly, it is better to have a long feed cycle followed by a delay that allows the sanitizer to circulate past the sensor. This will ensure proper readings from the sensor.

1. Timed Feed Mode = ORP Switch #10 is OFF
2. Feed Cycle in Minutes = ORP Switch #8 is ON
3. Pool Mode = ORP Switch #7 is OFF  
Spa Mode = ORP Switch #7 is ON
4. Choose the desired feed and delay cycle times from the following options.

**Recommended Settings**

**ORP SWITCHES ONLY**

Feed Cycle	Switch #3	Switch #4	Delay Cycle	Switch #5	Switch #6
12 Minutes	OFF	ON	5 Minutes	OFF	OFF

**Optional Settings**

**ORP SWITCHES ONLY**

**Pool Mode (#7 OFF)**

Feed Cycle	Switch #3	Switch #4
12 Minutes	OFF	ON
16 Minutes	OFF	OFF
24 Minutes	ON	ON
32 Minutes	ON	OFF

**Spa Mode (#7 ON)**

Feed Cycle	Switch #3	Switch #4
2 Minutes	OFF	ON
4 Minutes	OFF	OFF
6 Minutes	ON	ON
8 Minutes	ON	OFF

Delay Cycle	Switch #5	Switch #6	Delay Cycle	Switch #5	Switch #6
2 Minutes	OFF	ON	1 Minutes	ON	ON
5 Minutes	OFF	OFF	2 Minutes	OFF	ON
10 Minutes	ON	OFF	5 Minutes	OFF	OFF
20 Minutes	ON	ON	10 Minutes	ON	OFF

## Watermatic G1000 or G7500 Feeder

These feeders can only operate with a short feed cycle followed by a delay, continuous or long feed cycles damage the feeders.

1. Timed Feed Mode = ORP and pH Switch #10 are OFF
2. Feed Cycle in Seconds = ORP Switch #8 is OFF  
pH Switch #7 is OFF
3. Pool Mode = ORP Switch #7 is OFF  
Spa Mode = ORP Switch #7 is ON
4. Choose the desired feed and delay cycle times from the following options.

### Recommended Settings

#### ORP SWITCHES

Feed Cycle	Switch #3	Switch #4	Delay Cycle	Switch #5	Switch #6
4.8 Seconds	ON	OFF	10 Minutes	ON	OFF

#### pH SWITCHES

Feed Cycle	Switch #3	Switch #4	Delay Cycle	Switch #5	Switch #6
4.8 Seconds	OFF	ON	10 Minutes	ON	OFF

### Optional Settings

#### ORP SWITCHES

##### Pool Mode (#7 OFF)

Feed Cycle	Switch #3	Switch #4
4.8 Seconds	ON	OFF
7.2 Seconds	OFF	OFF
9.6 Seconds	ON	ON
14 Seconds	OFF	ON

##### Spa Mode (#7 ON)

Feed Cycle	Switch #3	Switch #4
.6 Seconds	OFF	OFF
1.2 Seconds	ON	OFF
2.4 Seconds	OFF	ON
3.6 Seconds	ON	ON

<b>Delay Cycle</b>	<b>Switch #5</b>	<b>Switch #6</b>	<b>Delay Cycle</b>	<b>Switch #5</b>	<b>Switch #6</b>
5 Minutes	ON	ON	2 Minutes	ON	OFF
10 Minutes	ON	OFF	5 Minutes	OFF	OFF
20 Minutes	OFF	OFF	10 Minutes	OFF	ON
30 Minutes	OFF	ON	15 Minutes	ON	ON

### **pH SWITCH**

<b>Feed Cycle</b>	<b>Switch #3</b>	<b>Switch #4</b>
.6 Seconds	OFF	OFF
2.4 Seconds	ON	OFF
4.8 Seconds	OFF	ON
9.6 Seconds	ON	ON

<b>Delay Cycle</b>	<b>Switch #5</b>	<b>Switch #6</b>
2 Minutes	OFF	ON
5 Minutes	OFF	OFF
10 Minutes	ON	OFF
30 Minutes	ON	ON





2620 Commerce Way, Vista, CA 92081-8438 • 760-599-9600 • 1-800-822-7933

[www.polarispool.com](http://www.polarispool.com)

© 2005 Polaris Pool Systems, Inc. All rights reserved TL-429 905